

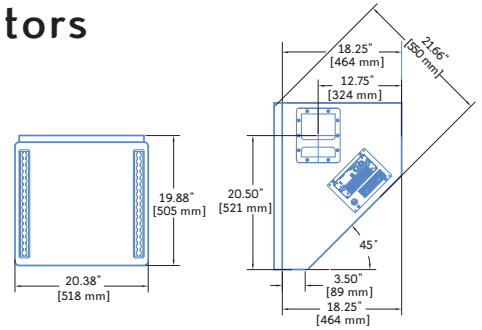

USM-1P/USM-100P : Extended Range Narrow/Wide Coverage Stage Monitors

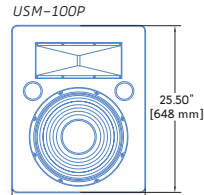
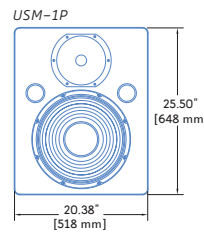

Dimensions	20.38" w x 25.50" h x 19.88" d (518 mm x 648 mm x 505 mm)
Weight	95 lbs (43.30 kg)
Enclosure	Premium birch plywood
Finish	Black textured
Protective Grille	Powder-coated hex-stamped steel, foam covering
Rigging	Two L-track strips on top panel; bottom strip for tilt angles (single-cabinet suspension only)

The USM-1P and USM-100P self-powered stage monitors are designed for high-level, full-bandwidth monitoring where significant reproduction of low-frequency information is desired. These units excel in cleanly reproducing stage mixes that include bass and drums, providing efficient response down to 30 Hz. The combination of high-performance drivers and perfectly matched drive electronics yields flat amplitude and phase response plus near-perfect impulse response over the full audio bandwidth — with benefits including lower susceptibility to feedback. Maximum SPL is 132 dB at one meter, with exceptionally low distortion.

Two high-frequency coverage patterns are available. The USM-1P provides a narrow, symmetrical beamwidth of 45 degrees horizontal and vertical, allowing close placement of monitors with minimal interaction between them. The USM-100P offers coverage of 100-degrees horizontal and 40-degrees vertical, permitting broad coverage in both stage monitoring and flown applications (using the integral L-Track hardware). The constant-Q design of the high-frequency

horns provides uniform beamwidth across the entire operating range in both the horizontal and vertical planes. Attenuation outside the beamwidth is rapid and uniform at all frequencies, with minimal side lobing.

Each driver is individually powered by a dedicated channel of the proprietary class AB/bridged amplifier with complementary MOSFET output stages. Total power is 550 watts. The incoming audio signal is processed through an electronic crossover and correction filters for flat phase and frequency response as well as for driver protection. Phase-corrected electronics ensure flat acoustical amplitude and phase response, resulting in exceptional impulse response and precise imaging.

Field-replaceable audio input modules accommodate a range of applications. The standard version offers looping XLR input and output connectors, while an enhanced looping version adds polarity switching (the looping output is not affected) and input attenuation (0 dB to -18 dB). A summing mono version with two inputs is also available.

The amplifier/processing package incorporates Intelligent AC™, which performs automatic voltage selection, EMI filtering, soft current turn-on and surge suppression for fail-safe worldwide operation.

The USM-P cabinet is constructed from premium birch plywood and covered in a black textured hard-shell finish. Recessed handles allow easy transit, a hex-stamped steel grille protects the speakers, and a removable grey foam front grille covering is included. The enclosure can be custom painted for applications requiring specific cosmetics. USM-P monitors can be deployed as stage wedges or flown as sidefill or choir monitors. Two L-Track strips on the top panel that work with the cabinet's center of gravity facilitate angle adjustment. A bottom strip serves as an anchor point for tilt angles. Rigging is for single cabinet suspension only.

USM-P monitors are compatible with the RMS™ remote monitoring system, which displays operating and performance parameters of Meyer Sound loudspeakers on a remote Windows® computer.

FEATURES & BENEFITS

- Extended low-frequency response for full-range sound reproduction
- USM-1P offers symmetrical, narrow constant-Q horn for precise coverage
- USM-100P offers broad horizontal coverage for both stage monitoring and flown applications
- Flat frequency and phase response maximizes gain before feedback
- May be used as conventional floor monitor or flown using integral L-Track hardware

APPLICATIONS

- Stage vocal monitor for medium- to large-scale applications
- Drum or keyboard monitor
- Frontfill, sidefill, or choir monitor when flown

USM-1P/USM-100P SPECIFICATIONS

ACOUSTICAL		Operating Frequency Range ¹ 30 Hz – 18 kHz Frequency Response ² 40 Hz – 17 kHz ±4 dB Phase Response 500 Hz – 16 kHz ±35° Maximum Peak SPL ³ 132 dB Dynamic Range >110 dB
COVERAGE		USM-1P: 45° x 45°; USM-100P: 100° horiz. x 40° vert.
CROSSOVER ⁴		USM-1P: 1000 Hz; USM-100P: 900 Hz
TRANSDUCERS		Low Frequency One 15" cone driver Nominal impedance: 2 Ω Voice coil size: 3" Power-handling capability: 400 W (AES) ⁵ High Frequency One 3" compression driver Nominal impedance: 16 Ω Voice coil size: 3" Diaphragm size: 3" Exit size: 1.4" throat Power-handling capability: 100 W (AES) ⁵
AUDIO INPUT		Type Differential, electronically balanced Maximum Common Mode Range ±15 V DC, clamped to earth for voltage transient protection Connectors Female XLR input with male XLR loop output or VEAM all-in-one (integrates AC, audio and network) Input Impedance 10 kΩ differential between pins 2 and 3 Wiring Pin 1: Chassis/earth through 220 kΩ, 1000 pF, 15 V clamp network to provide virtual ground lift at audio frequencies Pin 2: Signal + Pin 3: Signal – (optional polarity reversal switch) ⁶ DC Blocking Case: Earth ground and chassis CMRR Differential DC blocking up to maximum common mode voltage RF Filter >50 dB, typically 80 dB (50 Hz – 500 Hz) TIM Filter Common mode: 425 kHz; Differential mode: 142 kHz Nominal Input Sensitivity <80 kHz, integral to signal processing 0 dBV (1 V rms, 1.4 V pk) continuous average is typically the onset of limiting for pink noise and music Input Level Audio source must be capable of producing a minimum of +20 dBV (10 V rms, 14 V pk) into 600 Ω to produce maximum peak SPL over the operating bandwidth of the loudspeaker
AMPLIFIER		Type Two-channel complementary MOSFET output stages (class AB/bridged) Output Power ⁷ 550 W total THD, IM, TIM <.02 % Load Capacity 2 Ω low channel, 16 Ω high channel Cooling Convection; 24 V DC output for optional external fan
AC POWER		Connector PowerCon or VEAM Voltage Selection Automatic, continuous range from 90 V AC to 265 V AC Safety Agency Rated Operating Range 100 V AC – 240 V AC; 50/60 Hz Turn-on and Turn-off Points 90 V AC on, no turn-off, only fuse-protect above 265 V AC ⁸ Current Draw: Idle Current 0.25 A rms (115 V AC); 0.13 A rms (230 V AC); 0.3 A rms (100 V AC) Max Long-Term Continuous Current (>10 sec) 2.8 A rms (115 V AC); 1.4 A rms (230 V AC); 3.2 A rms (100 V AC) Burst Current (<1 sec) 3.2 A rms (115 V AC); 1.6 A rms (230 V AC); 3.7 A rms (100 V AC) Ultimate Short-Term Peak Current Draw 5.0 A pk (115 V AC); 2.5 A pk (230 V AC); 5.8 A pk (100 V AC) Inrush Current <9 A pk (115 V AC and 230 V AC)
RMS NETWORK (OPTIONAL)		Equipped for two-conductor, twisted-pair network, reporting amplifier operating parameters to system operator's host computer.

NOTES:

1. Recommended maximum operating frequency range. Response depends on loading conditions and room acoustics.
2. Half-space loading (monitor on the floor) measured with 1/3 octave frequency resolution at 1.5 meters.
3. Measured with music at 1 meter.
4. At this frequency, the mid- and high-frequency transducers produce equal sound pressure levels.
5. Power handling is measured under AES standard conditions: transducer driven continuously for two hours with band-limited noise signal having a 6 dB peak-average ratio.
6. Two additional input module options are available with a polarity reversal switch and an attenuator (0 dB to -18 dB): one looping and one with two inputs for mono summing.
7. Amplifier wattage rating based on the maximum unclipped burst sine-wave rms voltage that the amplifier will produce into the nominal load impedance. Low channel 30 V rms (42 V pk) into 2 ohms; high channel 32 V rms (45 V pk) into 16 ohms.
8. No automatic turn-off voltages. Voltages above 265 V AC are fuse protected but may cause permanent damage to the power supply. Voltages below 90 V AC may result in intermittent operation.

Made by Meyer Sound Laboratories
Berkeley, California USA

European Office:
Meyer Sound Lab. GmbH
Carl Zeiss Strasse 13
98751 Ploch, Germany

 N775

 CE



USM-1P/USM-100P – 04.089.005.01 B

Copyright © 2005
Meyer Sound Laboratories Inc.
All rights reserved

MEYER SOUND LABORATORIES INC.
2832 San Pablo Avenue
Berkeley, CA 94702

T: +1 510 486.1166
F: +1 510 486.8356

techsupport@meyersound.com
www.meyersound.com

ARCHITECT SPECIFICATIONS

The loudspeaker shall be a self-powered stage monitor; two models shall be available. The transducers shall consist of a 15-inch diameter cone driver and a 3-inch diaphragm compression driver on a 45-degree symmetrical or a 100-degree horizontal x 40-degree vertical horn, depending on the model.

The loudspeaker system shall incorporate internal processing electronics and a two-channel amplifier. Processing functions shall include equalization, phase correction, signal division and protection for the high- and low-frequency sections. The crossover point shall be 1000 Hz or 900 Hz, depending on the model. Each amplifier channel shall be class AB/bridged with complementary MOSFET output stages. Burst capability shall be 550 watts total with nominal 16-ohm resistive load for the high-frequency channel and 2-ohm for the low-frequency channel. Distortion (THD, IM, TIM) shall not exceed 0.02%.

Performance specifications for a typical production unit shall be as follows, measured at 1/3-octave resolution: Operating

frequency range shall be 30 Hz to 18 kHz. Phase response shall be ±35° from 500 Hz to 16 kHz. Maximum peak SPL shall be 132 dB at 1 meter. Horizontal coverage shall be 100 degrees and vertical coverage shall be 40 degrees, or 45 degrees symmetrical, depending on the model.

The audio input shall be electronically balanced with a 10 kOhm impedance and accept a nominal 0 dBV (1 V rms, 1.4 V pk) signal. Connector shall be XLR (A-3) type female with parallel looping male. RF filtering shall be provided, and CMRR shall be greater than 80 dB from 50 Hz to 500 Hz. Two additional input module options shall be offered with an attenuator and polarity reversal switch; one with loop-through output, and another with two summing inputs instead of the loop-through input and output.

The internal power supply shall perform automatic voltage selection, EMI filtering, soft current turn-on and surge suppression. Powering requirements shall be nominal 100, 110 or 230

V AC line current at 50 or 60 Hz. UL and CE operating voltage range shall be 100 to 240 V AC. Maximum peak current draw during burst shall be 5 A at 115 V AC, 2.5 A at 230 V AC and 5.8 A at 100 V AC. Current inrush during soft turn-on shall not exceed 9 A at 115 V AC. AC power connectors shall be PowerCon or VEAM all-in-one multi-pin connector.

The loudspeaker system shall provide facilities for installing Meyer Sound's optional RMS remote monitoring system. All components shall be mounted in an acoustically vented wedge-shaped enclosure constructed of premium birch plywood with a black textured hard-shell finish. The front grille shall be hex-stamped steel covered by charcoal gray foam. Dimensions shall be 20.38" wide x 25.50" high x 19.88" deep (518 mm x 648 mm x 505 mm). Weight shall be 95 lbs (43.30 kg). The enclosure front angle shall be 45 degrees.

The loudspeakers shall be the USM-1P and USM-100P.